

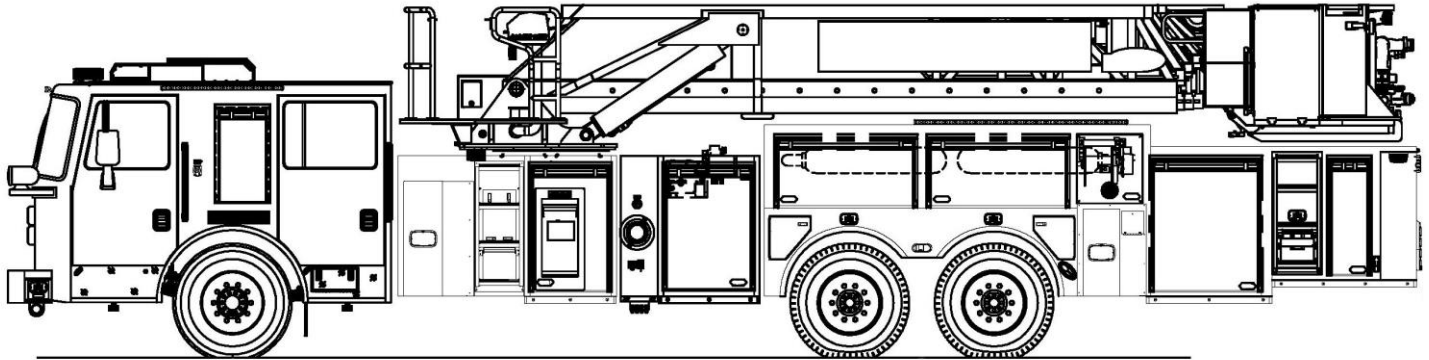

## CITY OF HAZLETON (PA)

# AerialCat™ Midmount Platform

GSO 11412



### CHASSIS

- KME Severe Service XMFD cab with flat roof
- Cummins X15 engine, 605 HP, 1,850 ft. torque; Allison 4500 EVSR transmission with retarder
- Valor seating for five firefighters
- Two cab external EMS compartments with internal access
- 110,000 PSI steel triple frame rail
- Hendrickson STEERTEK 24,000-pound front axle and suspension
- Meritor rear axle with 58,000-pound Raydan Air Ride Suspension

### ELECTRIC & WARNING

- Whelen warning light system
- HiViz brow and scene lights
- FRC scene lights on aerial platform
- 10 kW hydraulic generator
- Two Hannay electric reels with 200' of 10/4 cable

### BODY FEATURES

- 1/8-inch aluminum body with steel subframe
- Full-depth compartments on driver's and officer's sides
- Mitered body corners for reduced tail swing
- Six-bottle cascade system with Bauer fill station
- Storage for more than 150 feet of ground ladders in torque box

### AERIAL

- 84-foot aerial platform with 2.5:1 safety factor
- Aerial manufactured from 100,000 PSI steel for maximum strength
- Plus 80 degrees to minus 12 degrees aerial elevation
- 50 MPH wind rating with 1/4 inch of ice buildup
- 1,000-pound platform capacity through complete operating envelope of aerial
- 500-pound platform capacity while flowing water
- TFT Monsoon RC monitor with flow up to 2,000 GPM
- Amdor Pathfinder aerial lighting

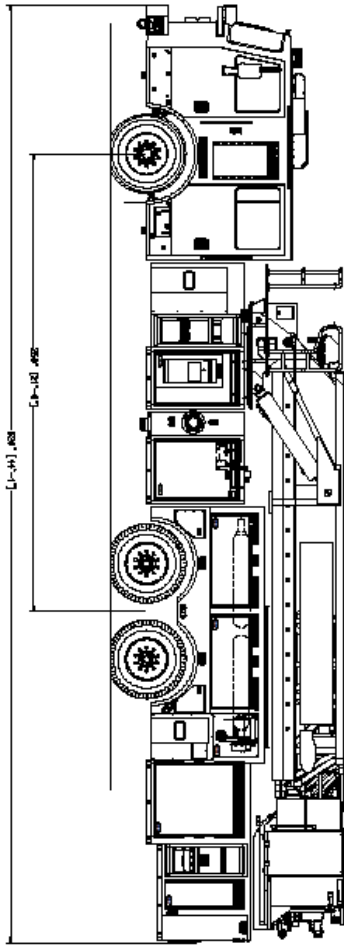
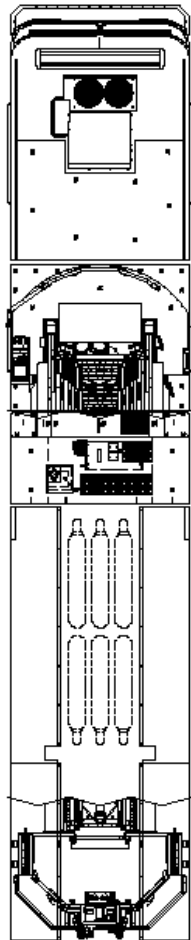
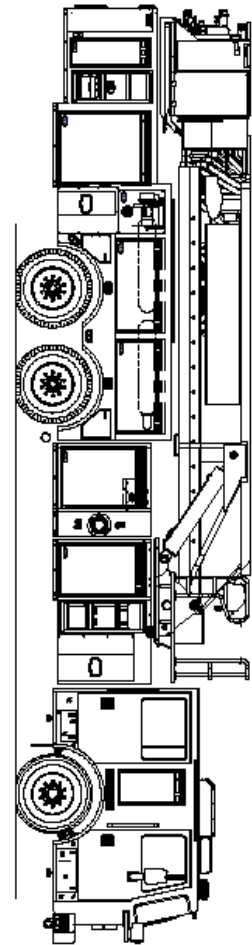
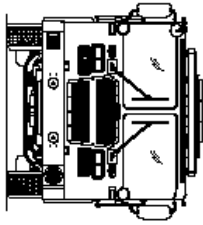
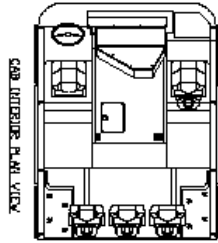
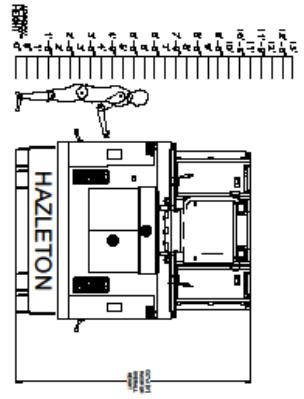

GENERAL INFORMATION		MANUFACTURER'S NAME	
1. MAKE	2. MODEL	3. MANUFACTURER'S NAME	4. MODEL
5. YEAR	6. BODY TYPE	7. MANUFACTURER'S NAME	8. MODEL
9. TYPE/CLASS	10. LAYOUT	11. MANUFACTURER'S NAME	12. MODEL
13. BODY TYPE	14. NUMBER OF PUMP PUMP/ROLL LITERS	15. MANUFACTURER'S NAME	16. MODEL
17. DATE	18. EQUIPMENT DESCRIPTION	19. MANUFACTURER'S NAME	20. MODEL
MULTI-DEPARTMENT : NONE		GSO# 11412	

