

APPROX. HEIGHT

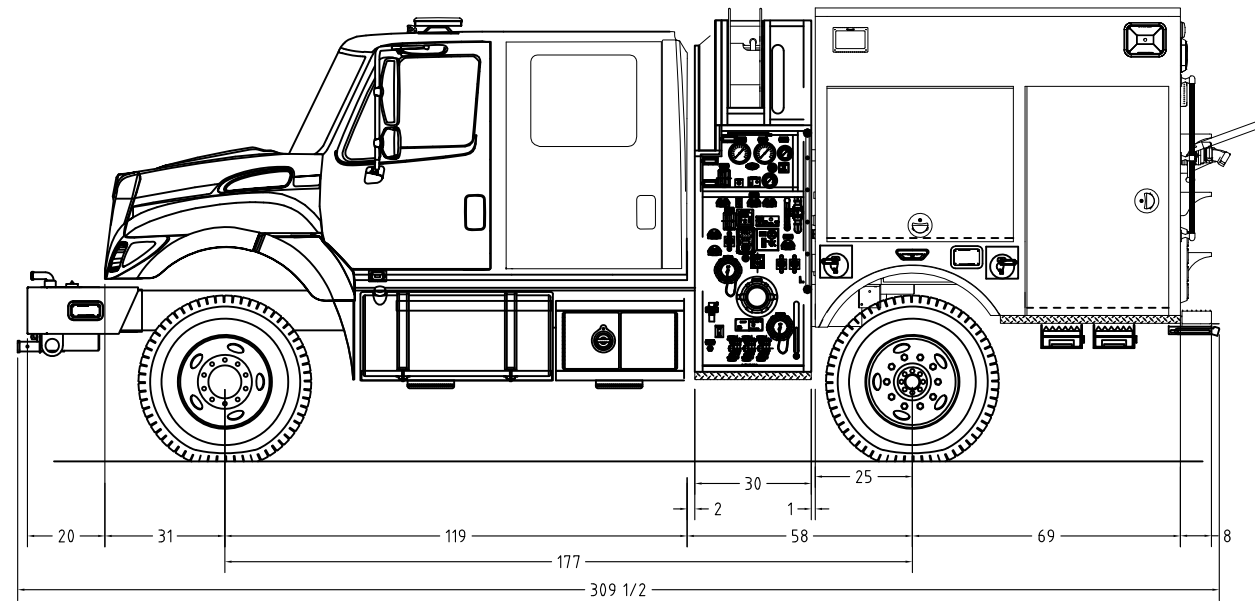
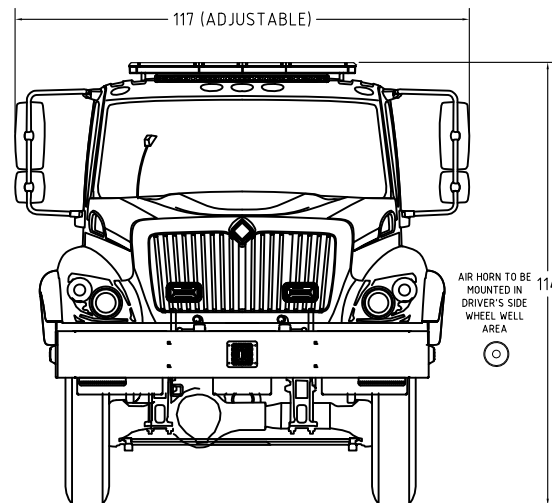
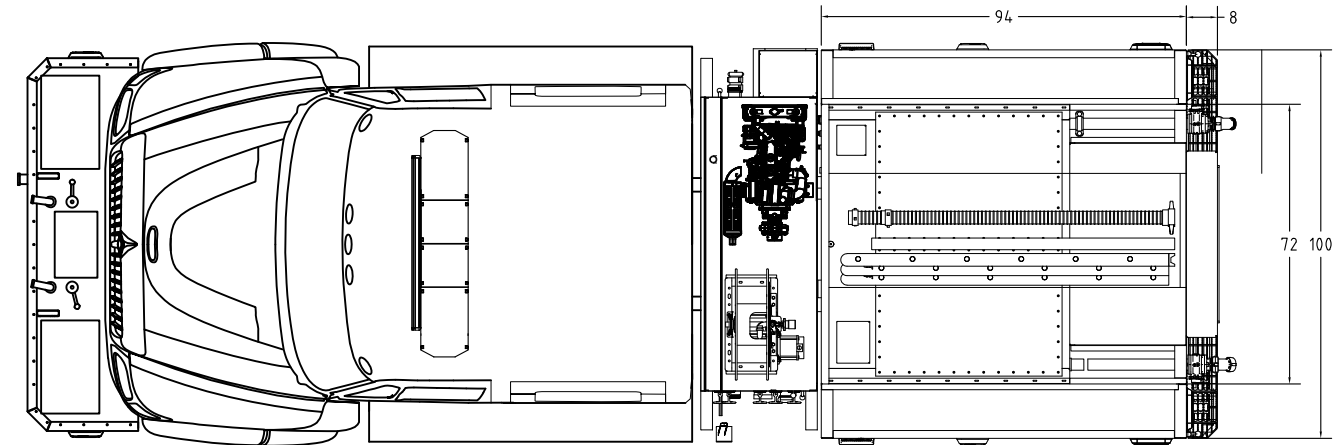
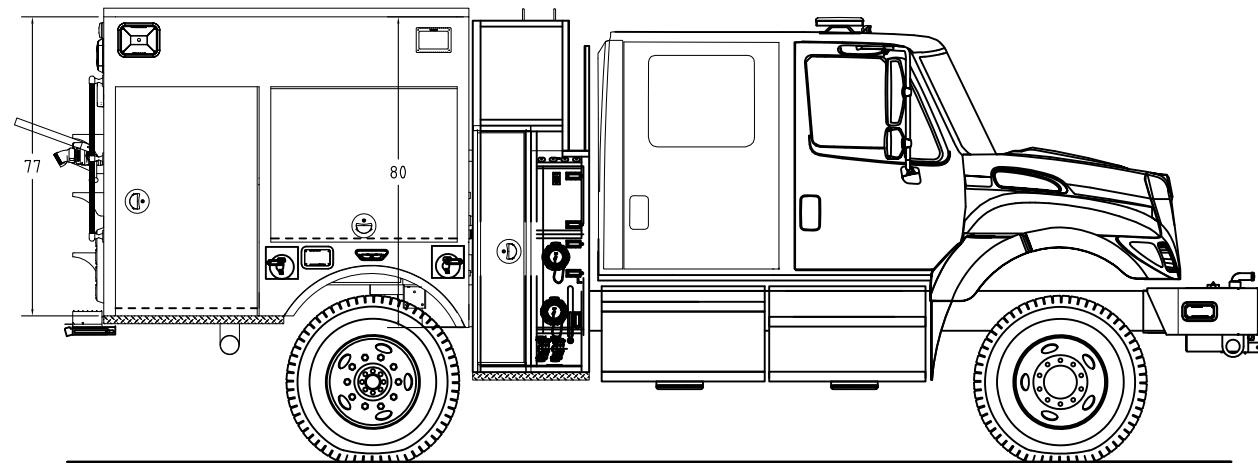

INTL HV507 SFA 4X4 CREW CAB
 CUMMINS L9 350HP/ALLISON 3000 EVS
 DARLEY JHP 500 GPM PTO PUMP
 DARLEY 1-1/2 AGE 24K DIESEL AUX. PUMP
 500 GALLON SS TANK / 20 GALLON FOAM
 94" INTERFACE BODY/12 GA GALV
 FOAM SYSTEM: FOAMPRO 1600

THIS DRAWING IS A GENERAL CONFIGURATION AND MAY NOT NECESSARILY REFLECT ALL CONTRACTUAL REQUIREMENTS. CONTRACT SPECIFICATIONS SHALL PREVAIL OVER DRAWING.

CUSTOMER APPROVAL:

NAME: _____
 TITLE: _____
 DATE: _____

SYM	DATE	REVISION DESCRIPTION	APP'D
A	10/30/2019	UPDATED TO MATCH PRECON LETTER	JCM
SALES ENGINEER : JAMES MECHLING			

DIMENSIONS ARE APPROXIMATE & MAY VARY DUE TO BUILD ADJUSTMENTS			
SCALE	DWG SIZE	DRAWN BY	DATE
1"=24"	D	JJM	9/30/2020
KME COMMERCIAL INTERFACE			
RETAIL UNIT			
GSO# 11054			

