

Notes:

1. Height dimensions will vary with loading.
2. Truck is capable of passing a 30 degree tilt table test under the expected loading

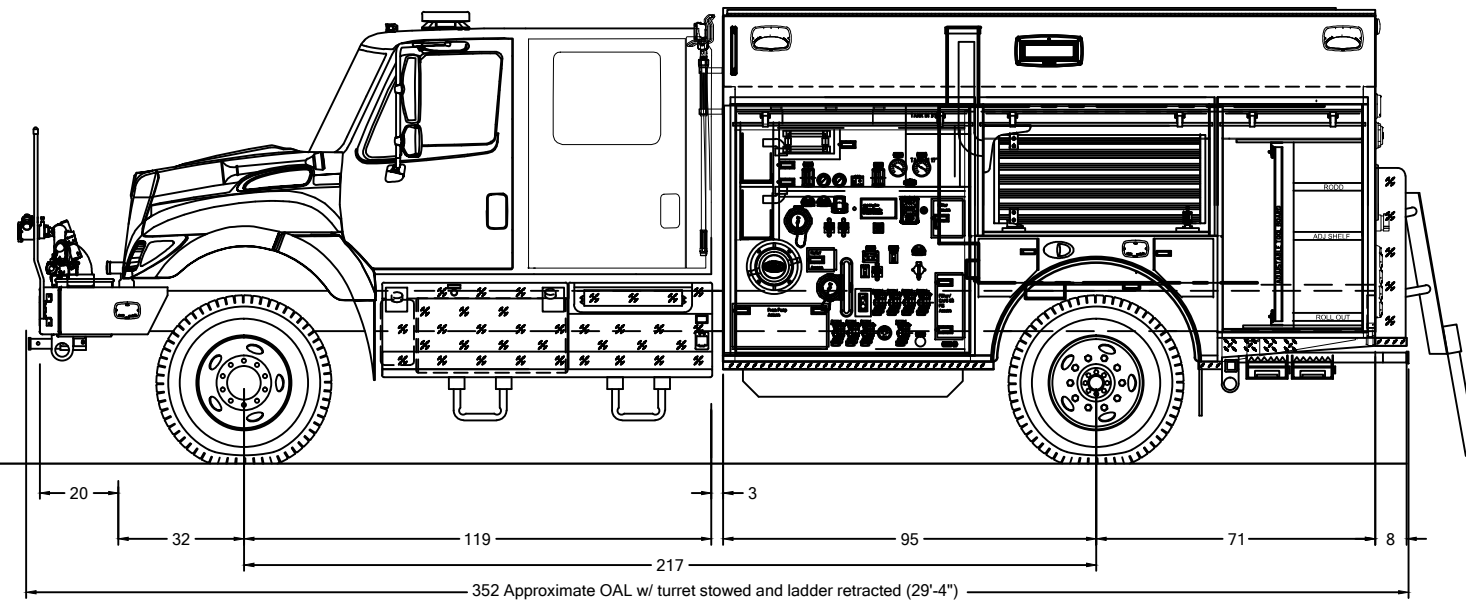
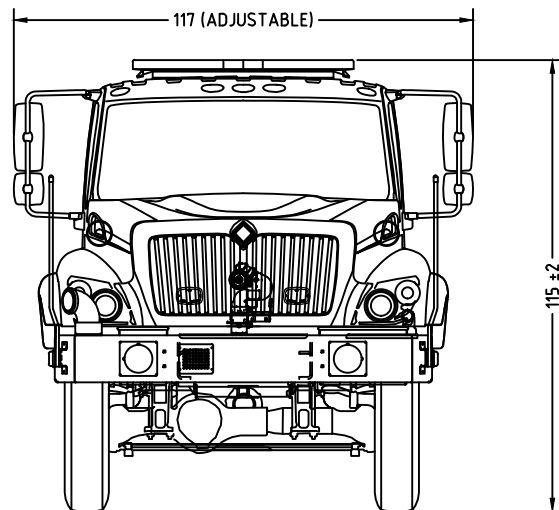
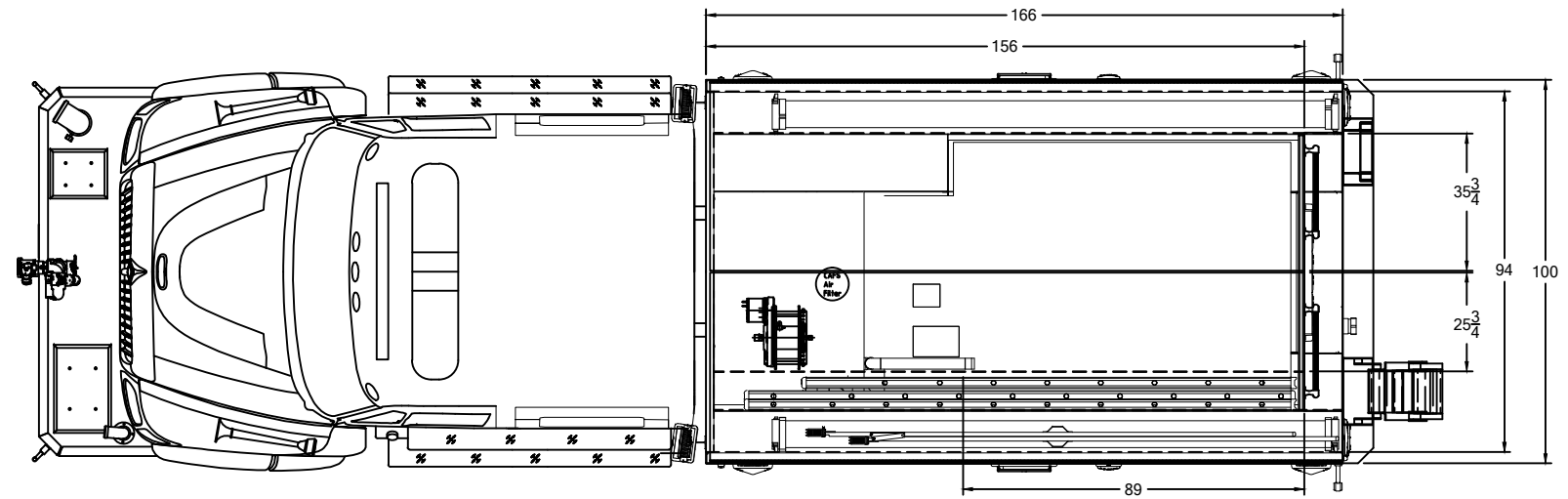

NAVISTAR 7400 4X4 CREW CAB
 MAXXFORCE 9 330HP DIESEL
 WATEROUS 1250 CXVPA W/ ONE STEP CAFS
 600 GALLON POLY TANK / 30 GALLON FOAM
 166" RIDGERUNNER BODY
 3/16" ALUMINUM

THIS DRAWING IS A GENERAL CONFIGURATION AND MAY NOT NECESSARILY REFLECT ALL CONTRACTUAL REQUIREMENTS. CONTRACT SPECIFICATIONS SHALL PREVAIL OVER DRAWING.

CUSTOMER APPROVAL:

NAME: _____
 TITLE: _____
 DATE: _____

SYM	DATE	REVISION DESCRIPTION	APP'D
B	9/22/2016	REVISED PER BODY RELEASE	MJH
A	2/8/2016	REVISED PER PRE-CON	MJH
SALES ENGINEER : MATT HIGGINS			

DIMENSIONS ARE APPROXIMATE & MAY VARY DUE TO BUILD ADJUSTMENTS
 SCALE 1"=24" DWG SIZE D DRAWN BY DBK DATE 12/22/2015
 APPROVED BY DBK

KME RIDGERUNNER
 SOUTHSIDE F.C., RIVERSIDE, PA

GSO#10330



KOVATCH MOBILE EQUIPMENT
 ONE INDUSTRIAL COMPLEX - NESQUEHONING, PA 18240