

HOSE LOAD =  
 300' OF 1 3/4"  
 200' OF 1 1/2"  
 400' OF 3"

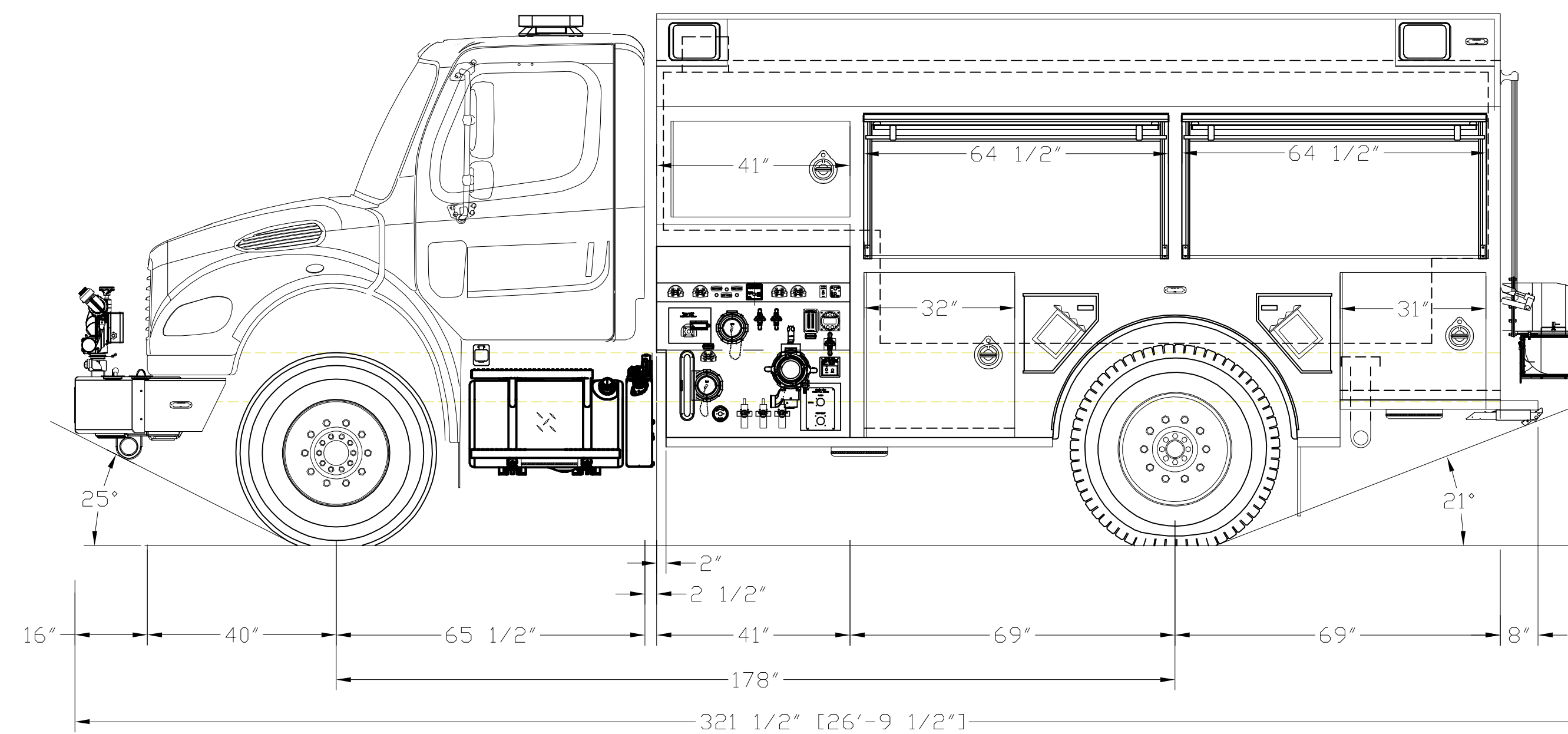
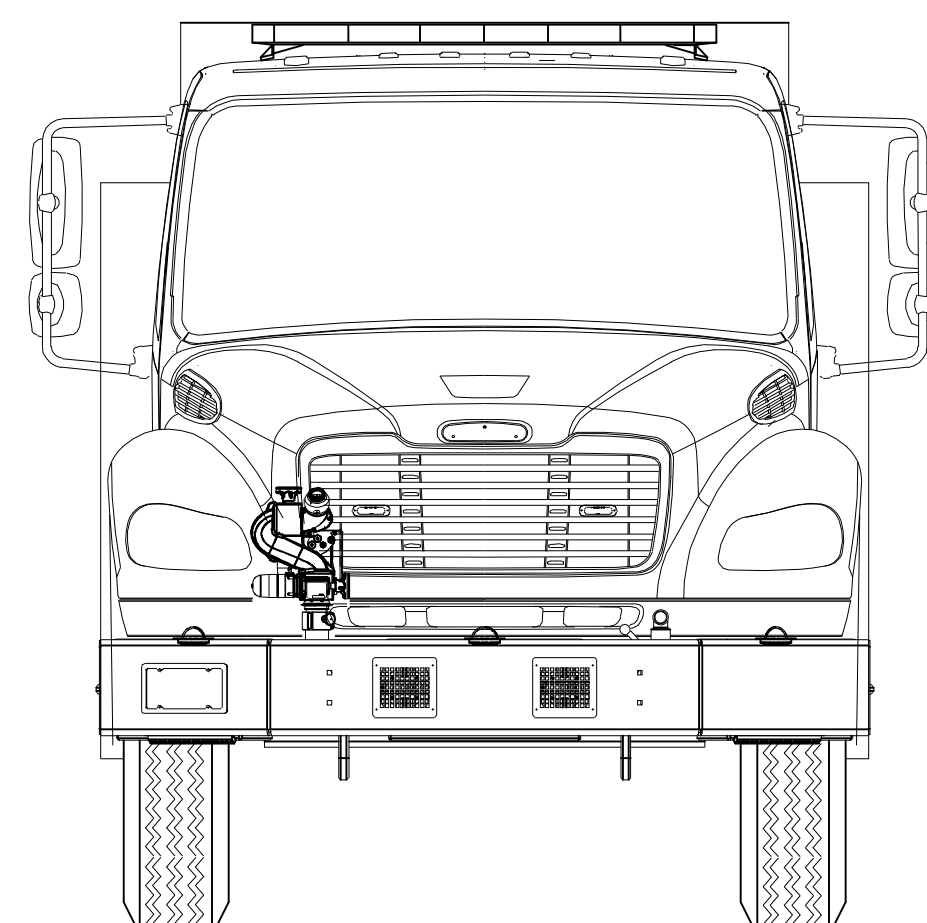
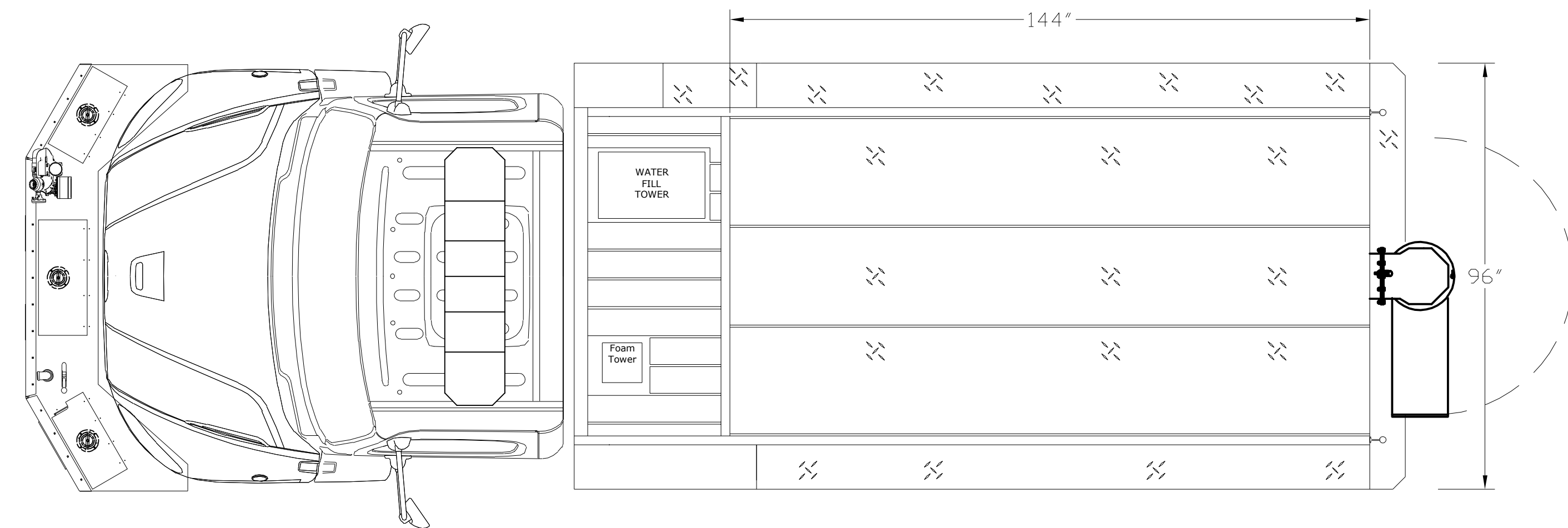
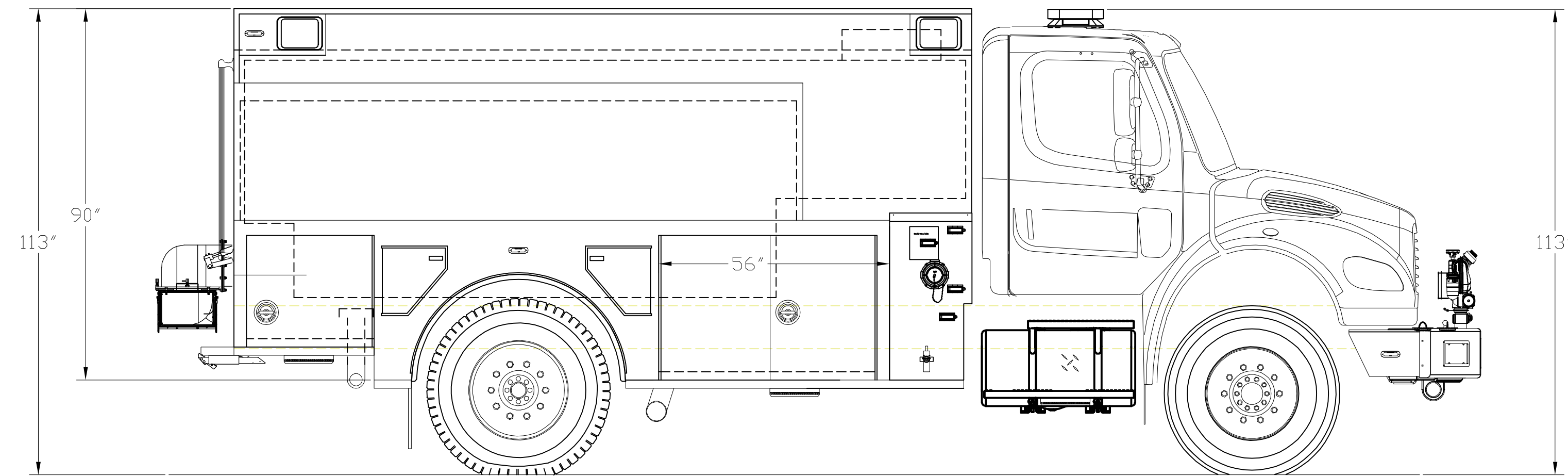
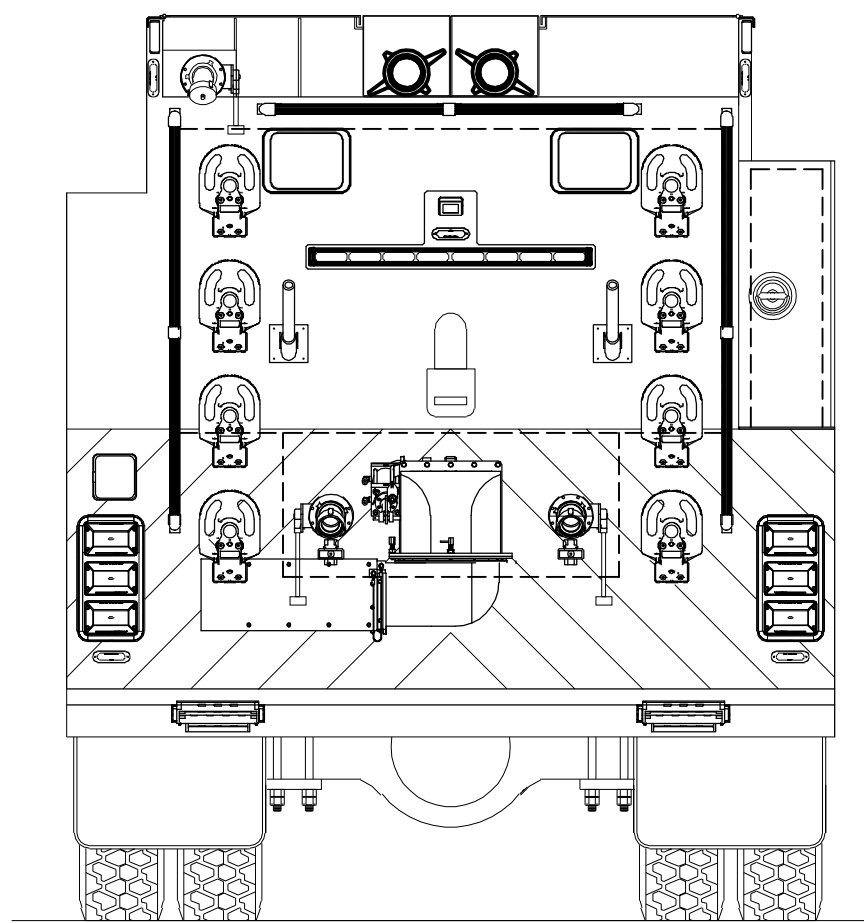

CAB: FREIGHTLINER M2 106 4X2 2 DR  
 ENGINE & TRANS: CUMMINS L9 350 HP/ALLISON 3000 EVS  
 AXLES: 14,000# FRONT/30,000# REAR  
 PUMP: DARLEY JMP 500 GPM SINGLE STAGE  
 WATER TANK: 2,000 GALLONS POLY W/20 FOAM  
 BODY TYPE: 138" ELIMINATOR 3/16" ALUMINUM  
 FOAM SYSTEM: FOAM PRO 2001

THIS DRAWING IS A GENERAL CONFIGURATION AND MAY NOT NECESSARILY REFLECT ALL CONTRACTUAL REQUIREMENTS. CONTRACT SPECIFICATIONS SHALL PREVAIL OVER DRAWING.

**CUSTOMER APPROVAL:**

NAME: \_\_\_\_\_  
 TITLE: \_\_\_\_\_  
 DATE: \_\_\_\_\_

SYM	DATE	REVISION DESCRIPTION	APP'D
C	02/13/2020	BODY ENGINEERING	JCM
B	12/17/2019	PRECONSTRUCTION REVISIONS	JCM
A	4-8-19	REVISED TO GSO#	AY
SALES ENGINEER : JAMES MECHLING			

DIMENSIONS ARE APPROXIMATE & MAY VARY DUE TO BUILD ADJUSTMENTS  
 SCALE: NONE DWG SIZE: B DRAWN BY: JJM DATE: 1-4-19  
 APPROVED BY: CK

**KME COMMERCIAL ELIMINATOR**  
**ORANGE COUNTY FIRE AUTH., CA**

**GSO#11136-37**



KME  
 ONE INDUSTRIAL COMPLEX - NESQUEHONING, PA 18240