

REAR VIEW

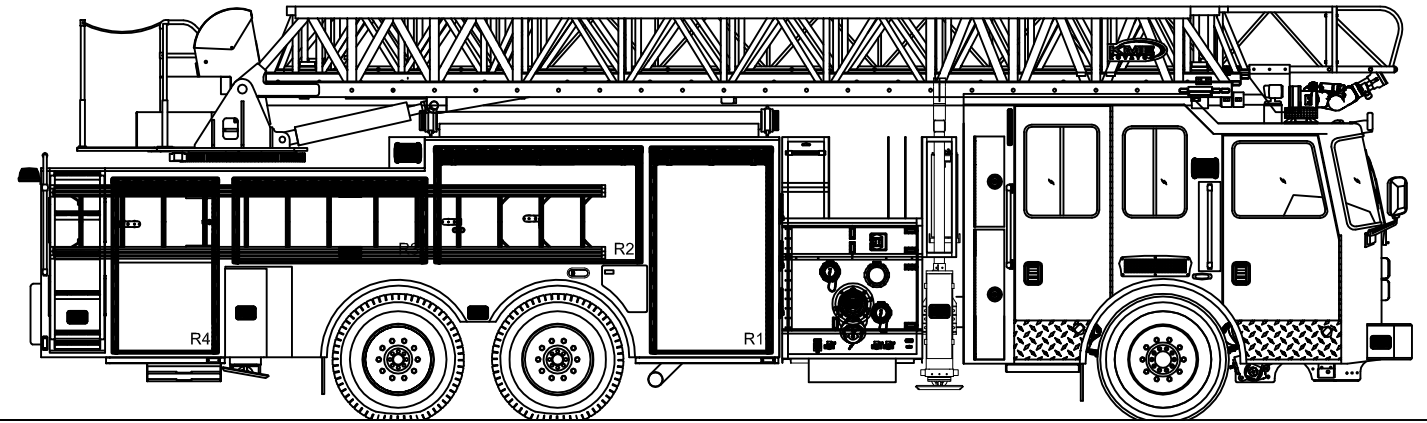

OFFICERS SIDE VIEW

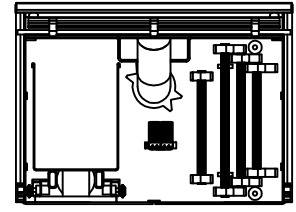
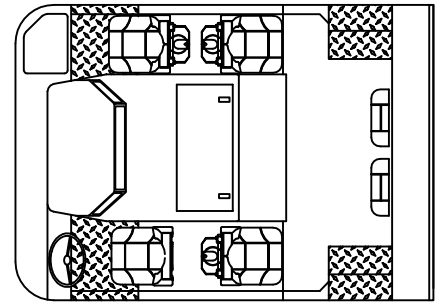

CAB INTERIOR LAYOUT

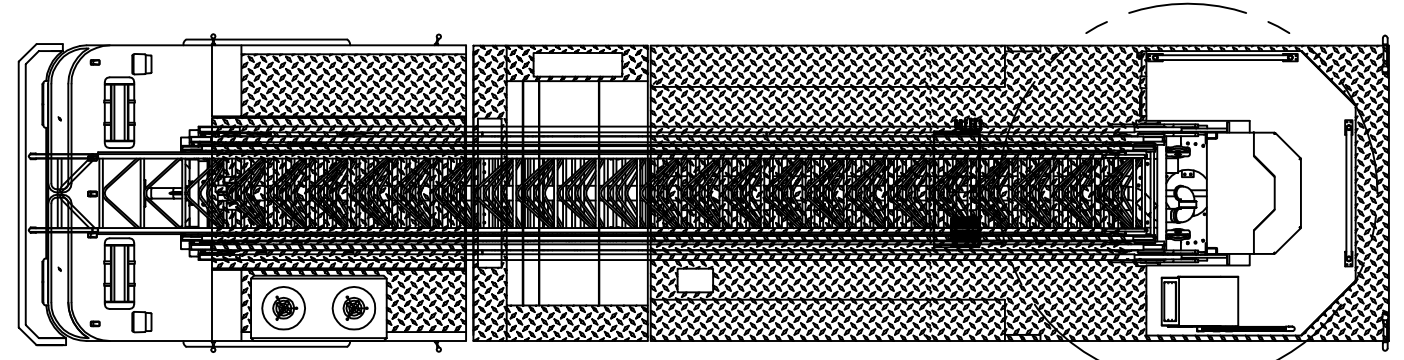

TOP VIEW

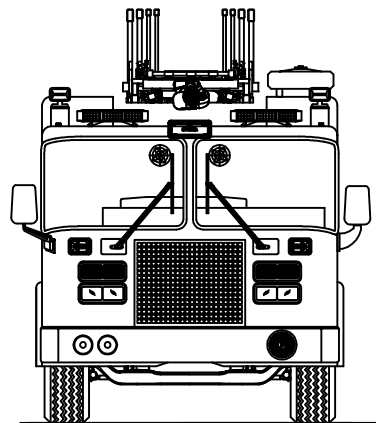

FRONT VIEW

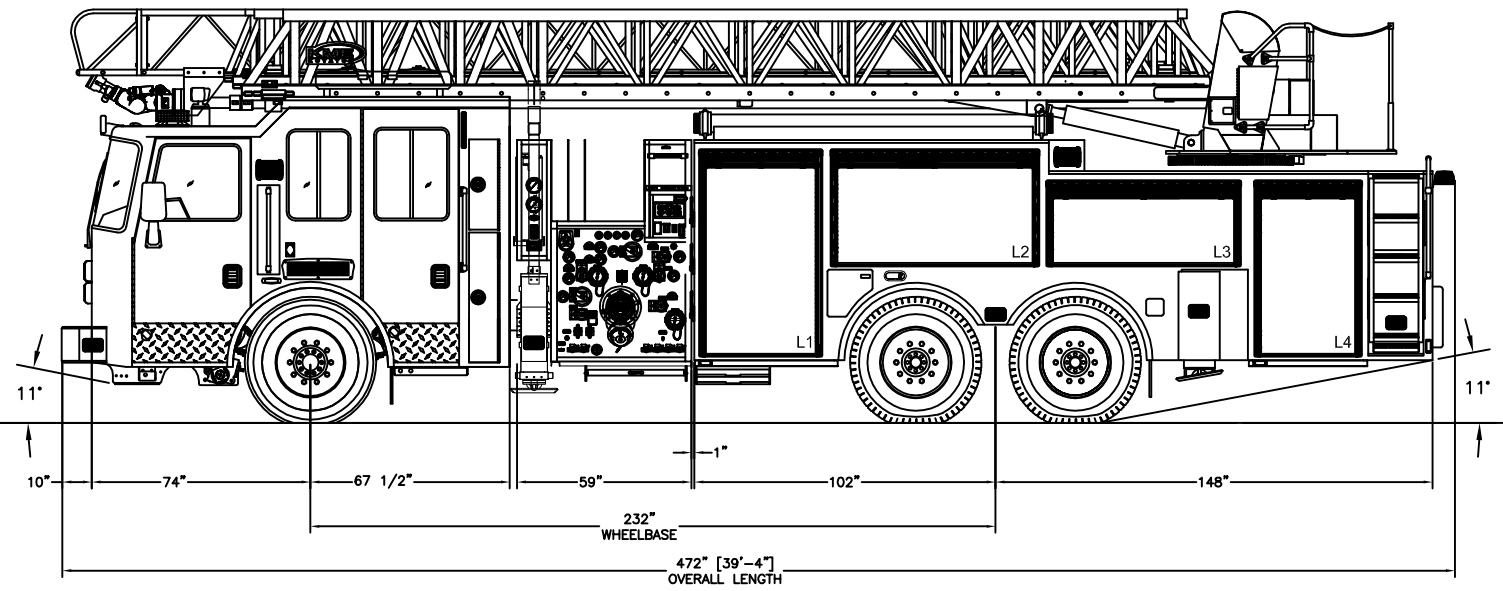

DRIVERS SIDE VIEW

CAB: PREDATOR SEVERE SERVICE 100" LFD 10" RAISED ROOF
 ENGINE/TRANSMISSION: CUMMINS X15 565HP w/ ALLISON 4500 EVS 6 SPEED
 AERIAL DEVICE: 103' REAR MOUNT LADDER
 PUMP: HALE QMAX-200 2,000 GPM SINGLE STAGE PUMPER
 TANK TYPE: 500 GALLONS
 BODY: 12GA 304L STAINLESS STEEL

SYM	DATE	REVISION DESCRIPTION	APP'D
SALES ENGINEER : T.B.D.			

DIMENSIONS ARE APPROXIMATE & MAY VARY DUE TO BUILD ADJUSTMENTS			
SCALE	DWG SIZE	DRAWN BY	DATE
NONE	B	Z.ZSCHUNKE	30NOV17
APPROVED BY P.HORCHAK			
103' REAR MOUNT LADDER			
HAMILTON, ON			
GSO #10836-37			

