

TREAD PLATE OVERLAY  
REAR VIEW OF CAB

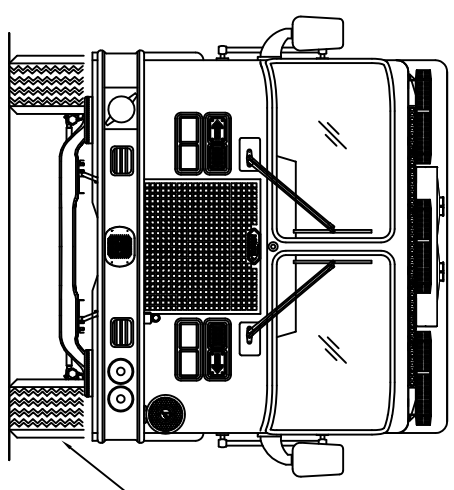

EZ-TRAC FRONT WHEEL DRIVE SYSTEM

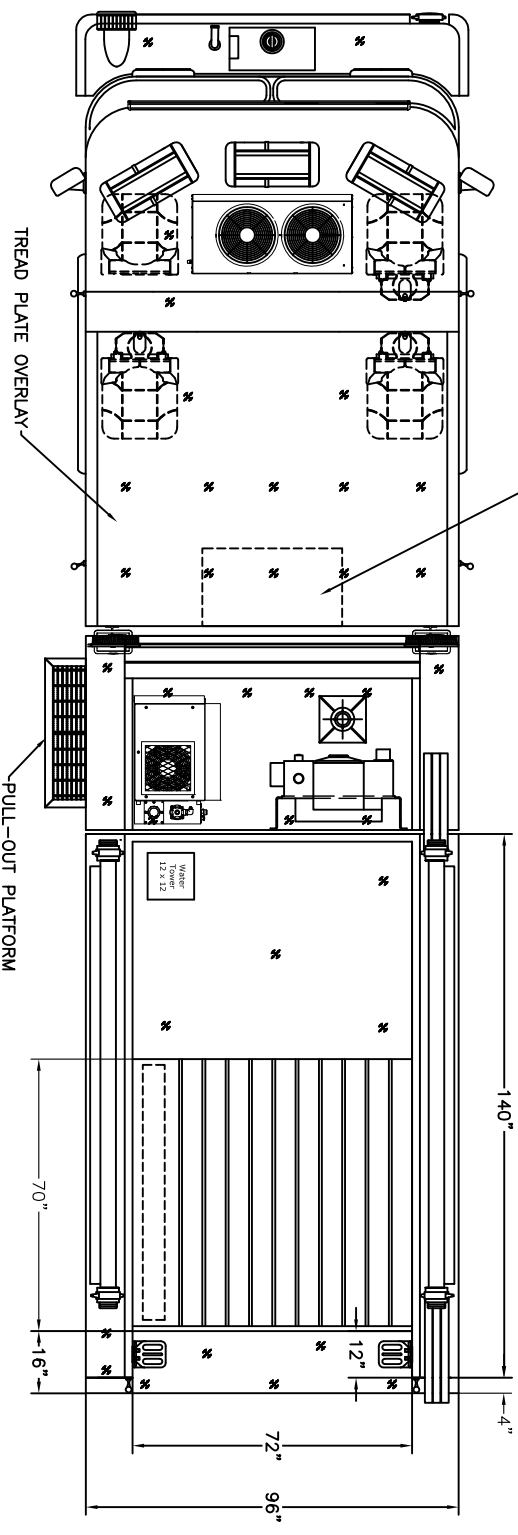
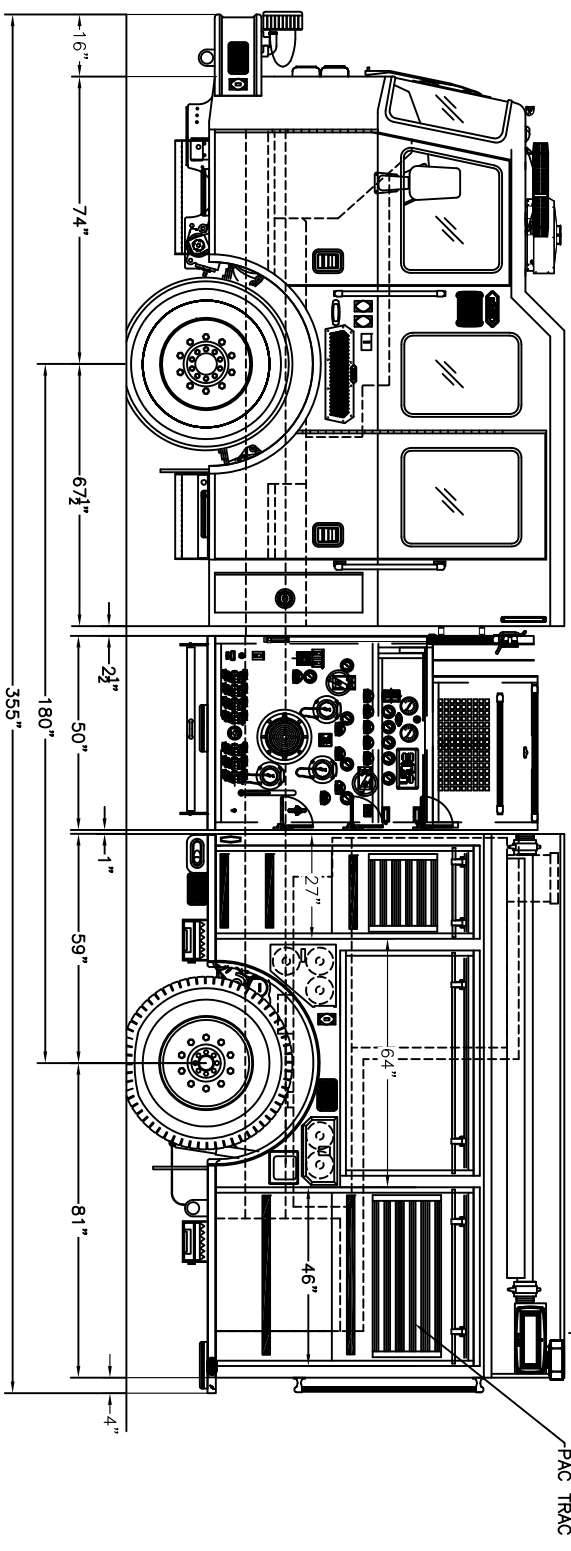

CAB: 96" WIDE KME SEVERE SERVICE LFD 10" RR  
ENGINE & TRANS: CUMMINS ISL9 400 HP/ALLISON 3000 EVS  
AXLES: 20,000# FRONT/27,000# REAR  
PUMP: HALE QMAX-150 1,500 GPM SINGLE STAGE PUMP  
WATER TANK: 750 GALLONS POLY  
BODY TYPE: 140" FLEX SHORT 3/16" ALUMINUM

THIS DRAWING IS A GENERAL CONFIGURATION AND MAY NOT NECESSARILY REFLECT ALL CONTRACTUAL REQUIREMENTS. CONTRACT SPECIFICATIONS SHALL PREVAIL OVER DRAWING.

CUSTOMER APPROVAL:

NAME:  
TITLE:  
DATE:

| REV | DATE    | DESCRIPTION                   |
|-----|---------|-------------------------------|
| E   | 5/1/18  | BODY LAYOUTS                  |
| C   | 7/21/17 | REMOVED A/C RAISED ROOF NOTCH |
| B   | 5/15/17 | PRE-CON WORKING               |
| A   | 4/24/17 | Q/E SPECS VERSION             |

| SCALE | DWG SIZE DRAWN BY | PER         | DATE       |
|-------|-------------------|-------------|------------|
| NONE  | B                 | APPROVED BY | 08/30/2016 |

DIMENSIONS ARE APPROXIMATE & MAY VARY DUE TO BUILD ADJUSTMENTS  
CUSTOM PUMPER  
CHAUTAQUA VOLUNTEER FIRE DEPT.  
GSO # 10653

