

FULLY RECESSED O2B
ON ANGLED AREA OF BUMPER

DO NOT EXCEED
MAX. HEIGHT 123" (10'-3")
MAX. LENGTH 408" (34'-0")

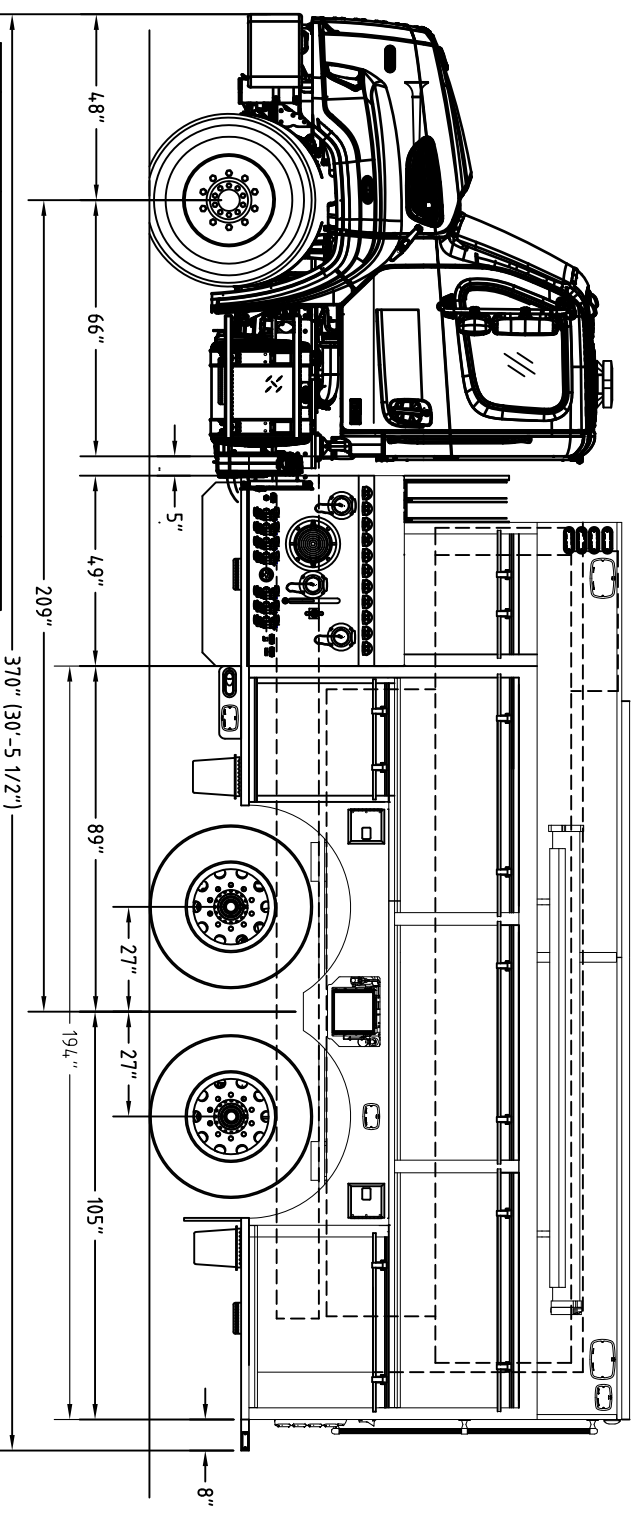
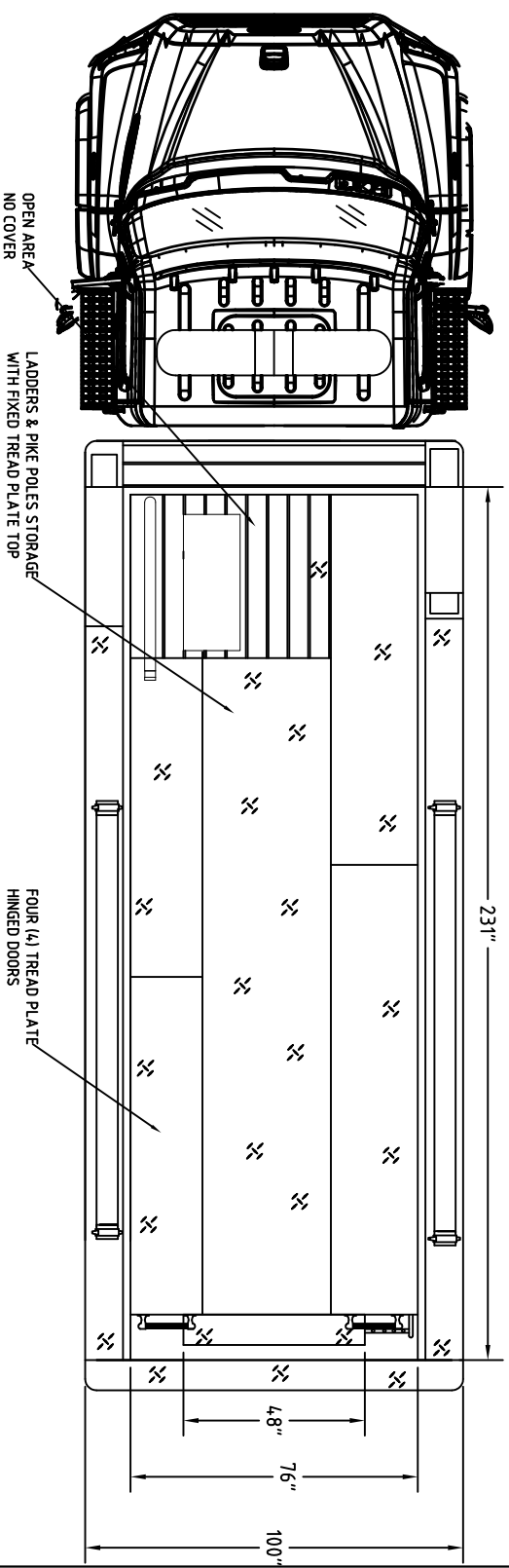
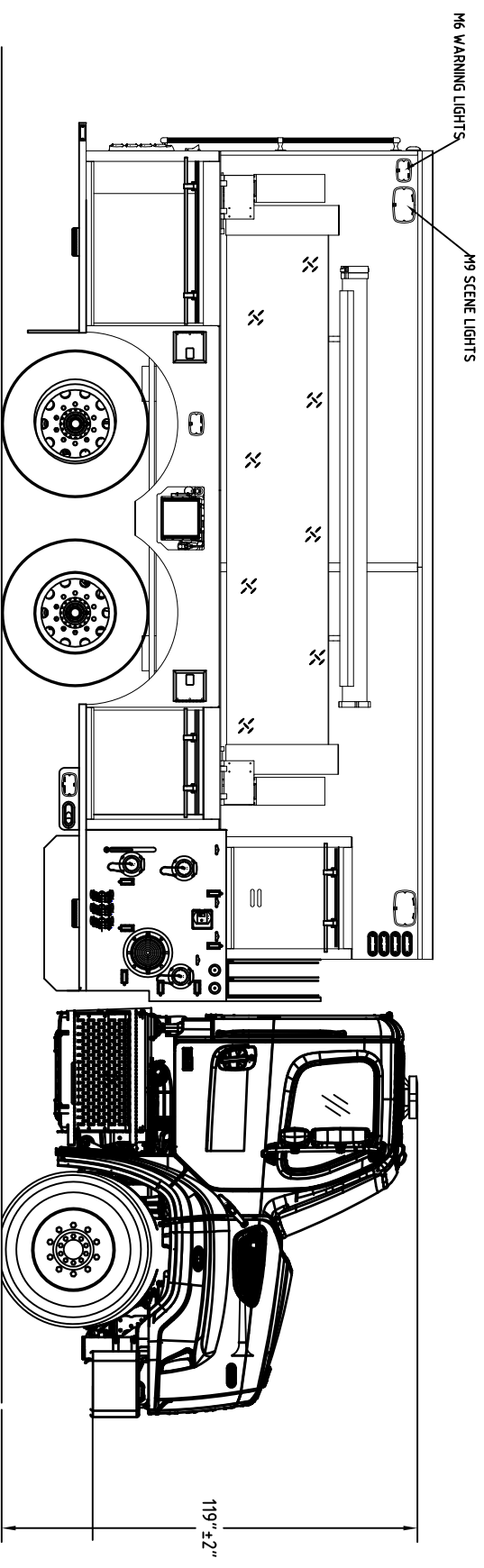

CAB: FREIGHTLINER 114SD 2-DOOR
ENGINE & TRANS: DETROIT DIESEL 505 HP/ALLISON 4000 EVS
AXLES: 20,000# FRONT/46,000# REAR
PUMP: WATEROUS CX 1,000 GPM SINGLE STAGE PUMP
WATER TANK: 3,000 GALLONS POLY
BODY TYPE: 221" FLATBACK ELIMINATOR

THIS DRAWING IS A GENERAL CONFIGURATION AND MAY NOT NECESSARILY REFLECT ALL CONTRACTUAL REQUIREMENTS. CONTRACT SPECIFICATIONS SHALL PREVAIL OVER DRAWING.

CUSTOMER APPROVAL:

NAME:
TITLE:
DATE:

F	11/1/17	ADDED REAR STEP EXT. & DS UPPER COMPT.	SG
E	8/14/17	INCREASED BODY LENGTH & REDUCED HEIGHT	SG
D	4/20/17	Added Rear Handrails on Side Views update OAL	SG
C	4/6/17	REVISED TO ENG. SPEC R REVIEW	SG
B	3/24/17	SPEC R	SG
A	1/12/17	PRE-CON	SG
SVM	DATE	REVISION DESCRIPTION	APPD

SALES ENGINEER : SHAWN GOGOLA

DIMENSIONS ARE APPROXIMATE & MAY VARY DUE TO BUILD ADJUSTMENTS

SCALE DWG SIZE DRAWN BY DATE

NONE B APPROVED BY T.MAF 11-16-16

COMMERCIAL TANKER

SHENANDOAH, VA

GSO #10605



KME
ONE INDUSTRIAL COMPLEX - NESQUEHONING, PA 18240