

114" MAXIMUM HEIGHT

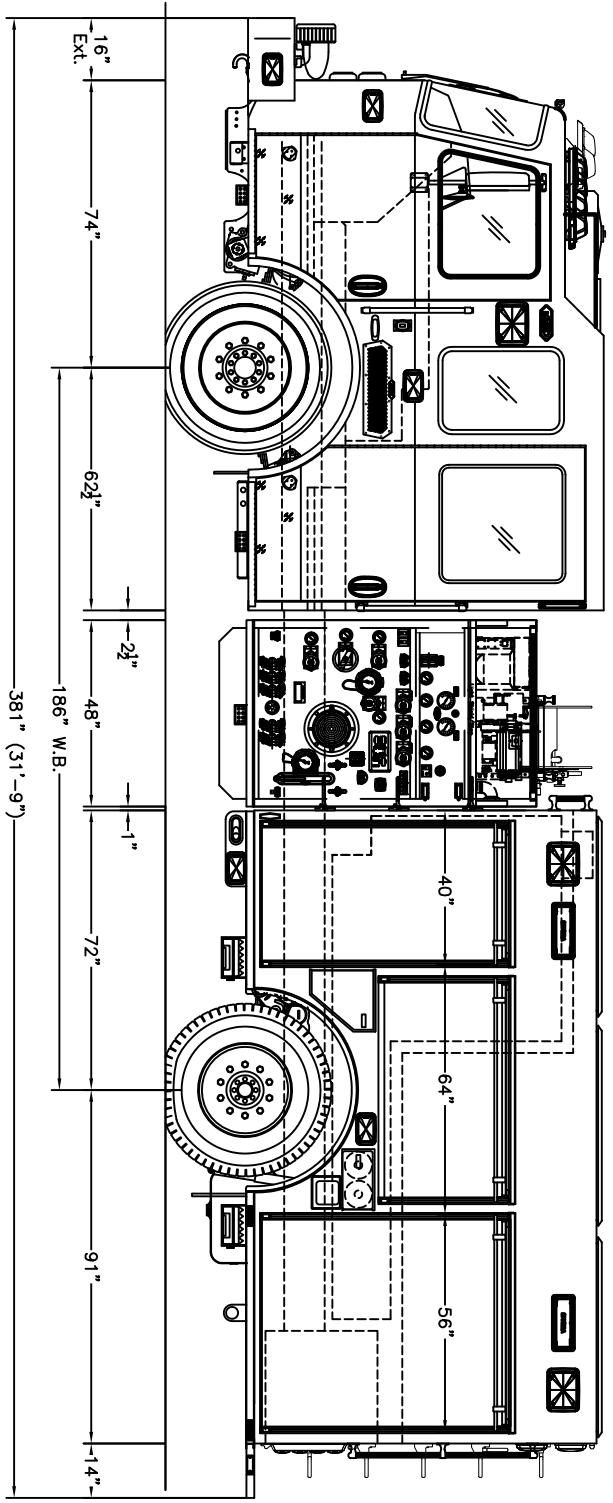
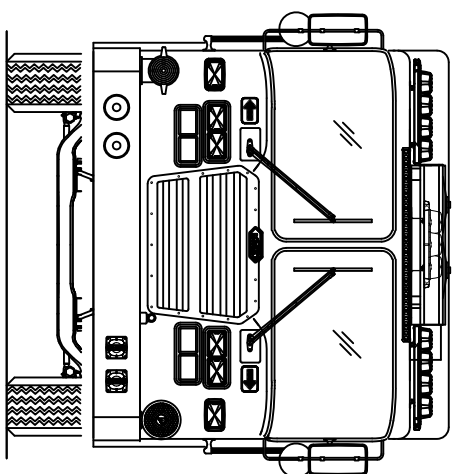
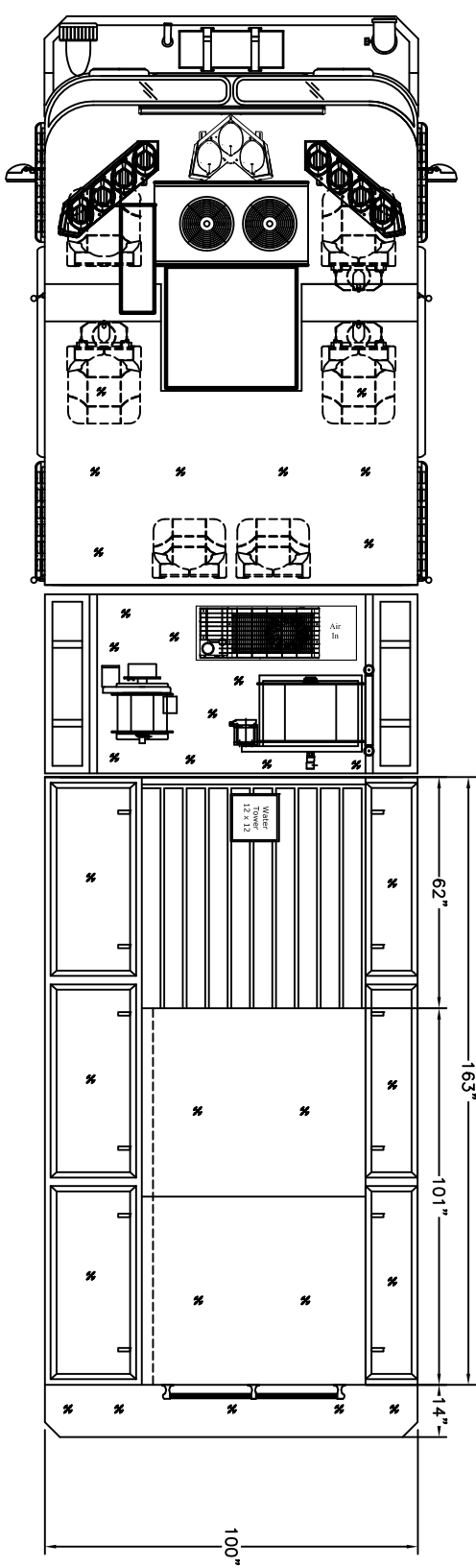
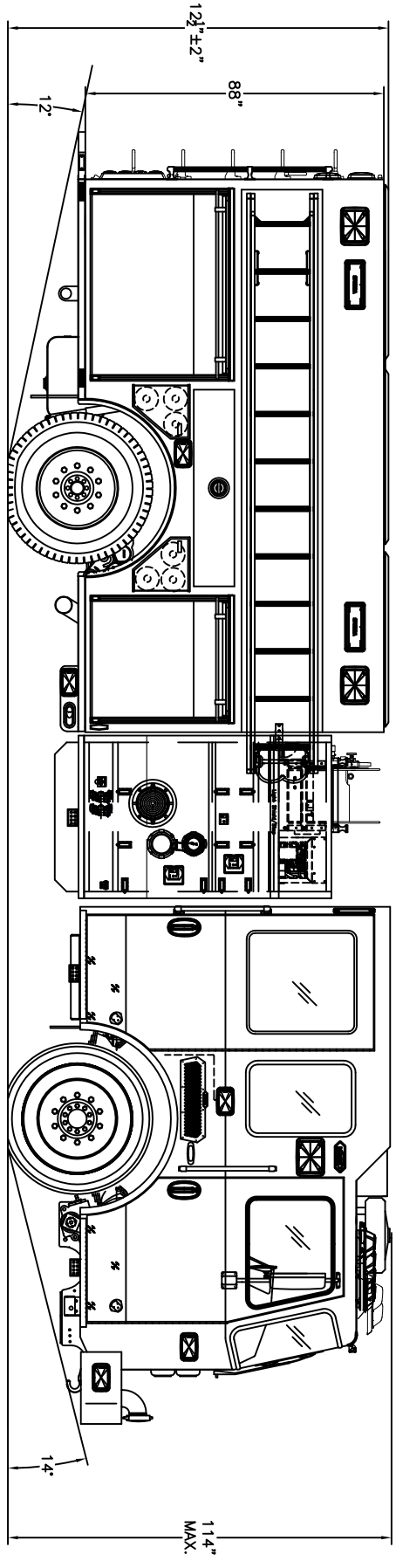

CAB: 100"W KME PANTHER MFD 10" RR
 ENGINE & TRANS: CUMMINS ISL9 450 HP/ALLISON 3000 EVS
 AXLES: 20,000# FRONT/27,000# REAR
 PUMP: WATEROUS CU-C20-1500 GPM T.B.D. STAGE PUMP
 WATER TANK: 750 GALLONS POLY
 BODY TYPE: .163" FLEX 3/16" ALUMINUM
 GENERATOR: SMART POWER HR-6 PTO/HYD

THIS DRAWING IS A GENERAL CONFIGURATION AND MAY NOT NECESSARILY REFLECT ALL CONTRACTUAL REQUIREMENTS. CONTRACT SPECIFICATIONS SHALL PREVAIL OVER DRAWING.

CUSTOMER APPROVAL:

NAME:
 TITLE:
 DATE:

SYM	DATE	REVISION DESCRIPTION	APP'D
C	6/26/17	UPDATED TO ENG LAYOUTS	SG
B	4/21/17	SPEC R	SG
A	2/27/2017	PRE-CON LETTER	SG

DIMENSIONS ARE APPROXIMATE & MAY VARY DUE TO BUILD ADJUSTMENTS
 SCALE NONE
 DVG SIZE DRAWN BY JIM
 APPROVED BY B
 DATE 9-2-16
 KME CUSTOM PUMPER
 BOROUGH of BRIDGEPORT, PA
 GSO #10589

